

GFS-400 GEN2

SOLAR STREET LIGHT



60W / 75W / 100W

187 lm/W (Max)



The GFS-400 offers an off-grid lighting solution where traditional lighting is too costly or impractical to install. It is consistently chosen by Local Government and NGO's across Australia due to its reliability and high power output.

It provides an entirely independant lighting solution for roadways, car parks, intersections and perimeter security wherever high performance is required without the costs of grid connection or energy supply.

APPLICATIONS

- Streets
- Roadways
- Intersections
- Car Parks
- Industrial
- Commercial
- Parks
- Recreation

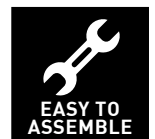

MODEL**GFS-400 (TUV certified to UL1598:2018)****OPERATING PROFILE / OPERATION MODE**

Standard 60W - **All night operation** - Unit operates at 100% until dawn.
 Standard 75W - **100% for 6 hours** - Unit operates at then dims to 20W until dawn
 Standard 100W - **100% for 4 hours** - Unit operates at then dims to 20W until dawn
NOTE: Configurable TIMER settings for ON / OFF / DIM are available upon request.

Power	60W
Lumen	187 lm/W (Max)
CCT	4000K
LED	CREE X-PG Adjustable angle
Lens	LEDIL T3 type. IK-10 rated
Optics	T3 135° x 85°
Operational Run Times	60W - 70W all night 100% power until dawn. / 100W -100% for 4hrs then dims to 15W until dawn
Solar Panel	454W(p) mono-crystalline 21% efficiency impact resistant tempered glass. stone-guard on back and bird guard
Pole	Octagonal high strength steel, Hot dipped galvanised with zinc coating (AS4680 Standards)
LED Outrigger	1.2m - 3m / 4'-10'
LED Mounting Height	5.4m / 17.7' - 8.8m / 28.8'(optional)
Sail Area / EPA (m ² / ft ²)	Solar panel : 1.1m ² / 11.84' ² Outrigger: 0.095m ² / 1.02' ² LED Fixture: 0.085m ² / 0.91' ²
Battery	2 x 12v 110Ah (2640Wh) Sealed GEL Batteries
Charge Controller	MPPT type with temperature and short circuit protection. Programmable custom settings
Operating Temp.	-20°C to 60°C / -4°F to 140°F
Certifications	AS/NZS 1158 V Category Roadway, ISO9001:2015 Quality assured company, RPEQ Certified Design.
Warranty	5 year warranty / 25 year solar panel warranty / 5 years + 5 years (pro-rata) battery warranty
Package Dimensions (Standard 6m pole)	Crate: 1650 x 880 x 560 mm / 65" x 35" x 22" Top pole: 3000 x 130 x 130 mm / 118.1" x 5.1" x 5.1" Bottom pole: 3000 x 510 x 310 mm / 118.1" x 20" x 12.2"
Package Weight (Standard 6m pole)	Crate: 189 kg / 372.5 lb Top pole: 27 kg / 59 lb Bottom pole: 83 kg / 183 lb Top pole: 35 KG / 77.1 lb
Options	<ul style="list-style-type: none"> • 8m / 26' Galvanised pole with external battery box • Concrete block for temporary / mobile lighting • 75W / 100W (18,700lm) • Twin LED / 180° / 90° • IoT SMART city monitoring and control system (SAM) • Anti -climbing spike collar • Light spill shield front / back • Outdoor rated ON / OFF switch • 3000K CCT • T5 Lens 110° x 135° • Goose neck outrigger extension • Cyclone wind region C / D

6m / 20' pole

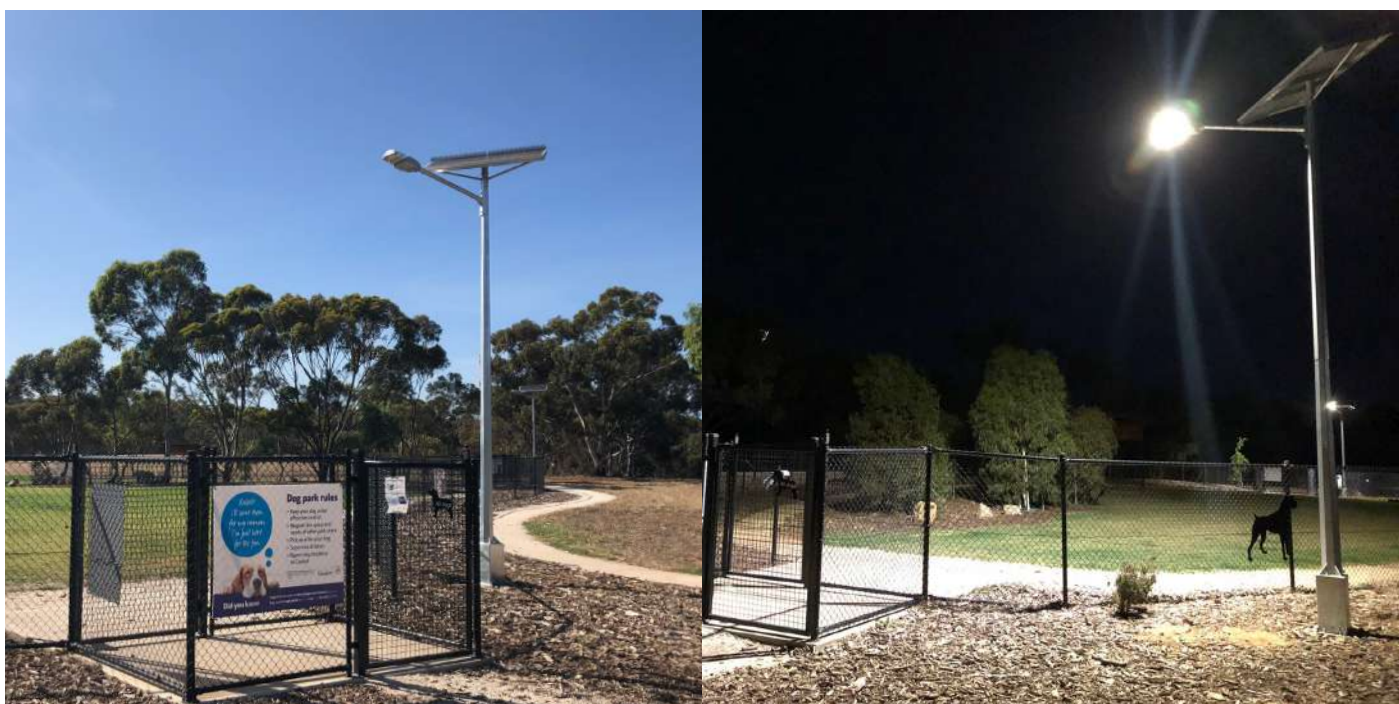
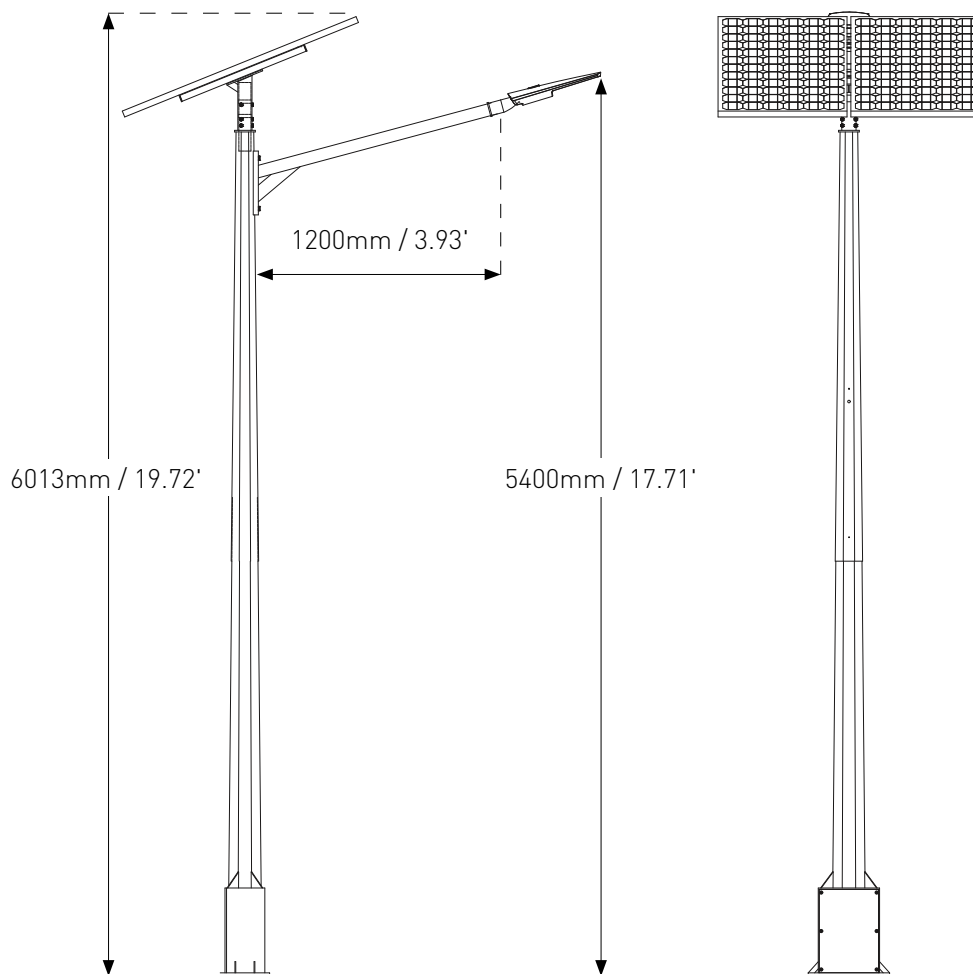

9.5m / 26' Mounting Options

