

# GFS-200 GEN3

## SOLAR STREET LIGHT



30W / 60W / 75W

5,610lm / 11,220lm / 14,025lm



The GFS-200 offers an environmentally friendly, off-grid street lighting solution that operates every night, all year round and avoids the costs of trenching, cabling and mains power connection.

It has been identified as the most reliable, robust, virtually unbreakable solar street light on the market and is consistently chosen by local councils and Government across the globe due to its reliability and ease of installation.

It provides a sustainable lighting option anywhere from the remote locations to inner city suburbia.

### APPLICATIONS

- Streets
- Minor Roads
- Pathways
- Car Parks
- Industrial
- Commercial
- Marinas / Jetties
- Parks / Recreation



**MODEL GFS-200 (TUV certified to UL1598:2018)****OPERATING PROFILE / OPERATION MODE**

Standard 30W	<b>Constant all night operation</b> - Unit operates at 30W until dawn
Optional 60W	<b>60W for 6 hours</b> - Unit operates at 60W then dims to 15W until dawn
Optional 75W	<b>75W for 4 hours</b> - Unit operates at 75W then dims to 15W until dawn

**NOTE:** Configurable TIMER settings for ON / OFF / DIM are available upon request

Power	30W -75W
Lumen	187 lm/W (Max)
CCT	4000K
LED	CREE X-PG3 Adjustable angle
Lens	T3 type / 135° x 85° / IK-10 rated
Solar Panel	227W(p) mono-crystalline 21% efficiency, impact resistant tempered glass, bird guard.

Pole	Octagonal high strength steel, Hot dipped galvanised with zinc coating (AS4680 Standards)
LED Outrigger	1.2m - 3m / 4'-10'
LED Mounting Height	Standard 5.4m / 17.7'   Optional 8.8m / 28.8'
Sail Area / EPA (m <sup>2</sup> / ft <sup>2</sup> )	0.536m <sup>2</sup> / 5.78 ft <sup>2</sup> @ 22° (fixed)

Battery	2 x 12v 110Ah (2640Wh) Sealed GEL Batteries
Charge Controller	MPPT type with temperature and short circuit protection. Programmable custom settings
Operating Temp.	-20°C to 60°C / -4°F to 140°F

Certifications	AS/NZS 1158, ISO9001:2015 Quality assured company, RPEQ Certified
----------------	---

Warranty	5 year / 25 year solar panel / 5 year battery*
----------	--

Package Dimensions (Standard 6m pole)	Crate: 1650 x 880 x 560 mm / 65" x 35" x 22" Top pole: 3000 x 130 x 130 mm / 118.1" x 5.1" x 5.1" Bottom pole: 3000 x 510 x 310 mm / 118.1" x 20" x 12.2"
--	---

Package Weight (Standard 6m pole)	Crate: 169 kg / 372.5 lb Top pole: 27 kg / 59 lb Bottom pole: 83 kg / 183 lb
--------------------------------------	--

Options	<ul style="list-style-type: none"><li>• 9.5m / 31' Galvanised pole with external battery box</li><li>• Concrete block for temporary / mobile lighting</li><li>• 60W (11,220lm) / 75W (14,025lm)</li><li>• Twin LED at 180° / 90°</li><li>• IoT SMART city monitoring and control system (SAM)</li><li>• Anti-climbing spike collar</li><li>• Light spill shield front / back</li><li>• Outdoor rated ON / OFF switch</li><li>• 3000K CCT</li><li>• T5 Lens 110° x 135°</li><li>• Goose neck outrigger extension</li><li>• Cyclone wind region C / D</li><li>• Hinged base plate</li></ul>
---------	---

\*Full warranty details are available at:  
<https://greenfrogsystems.com.au/product-warranty>

# 6m / 20' Pole

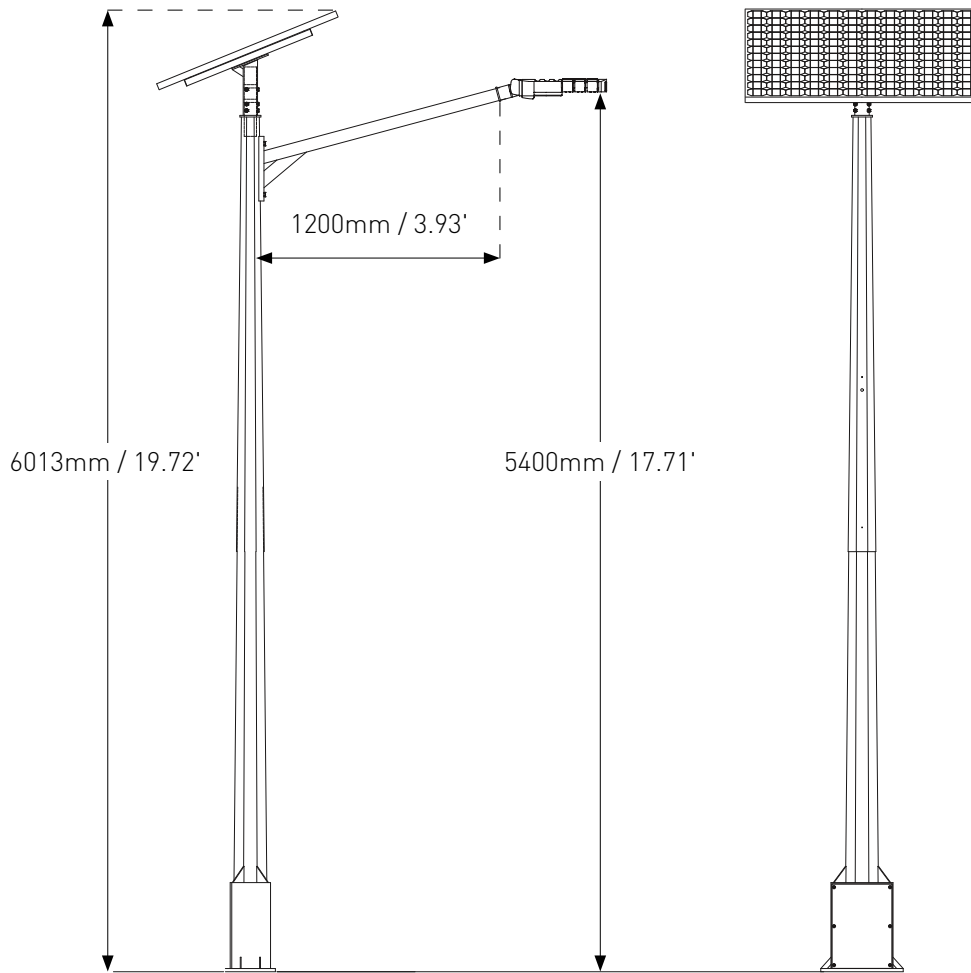

## 9.5m / 31' Pole Option

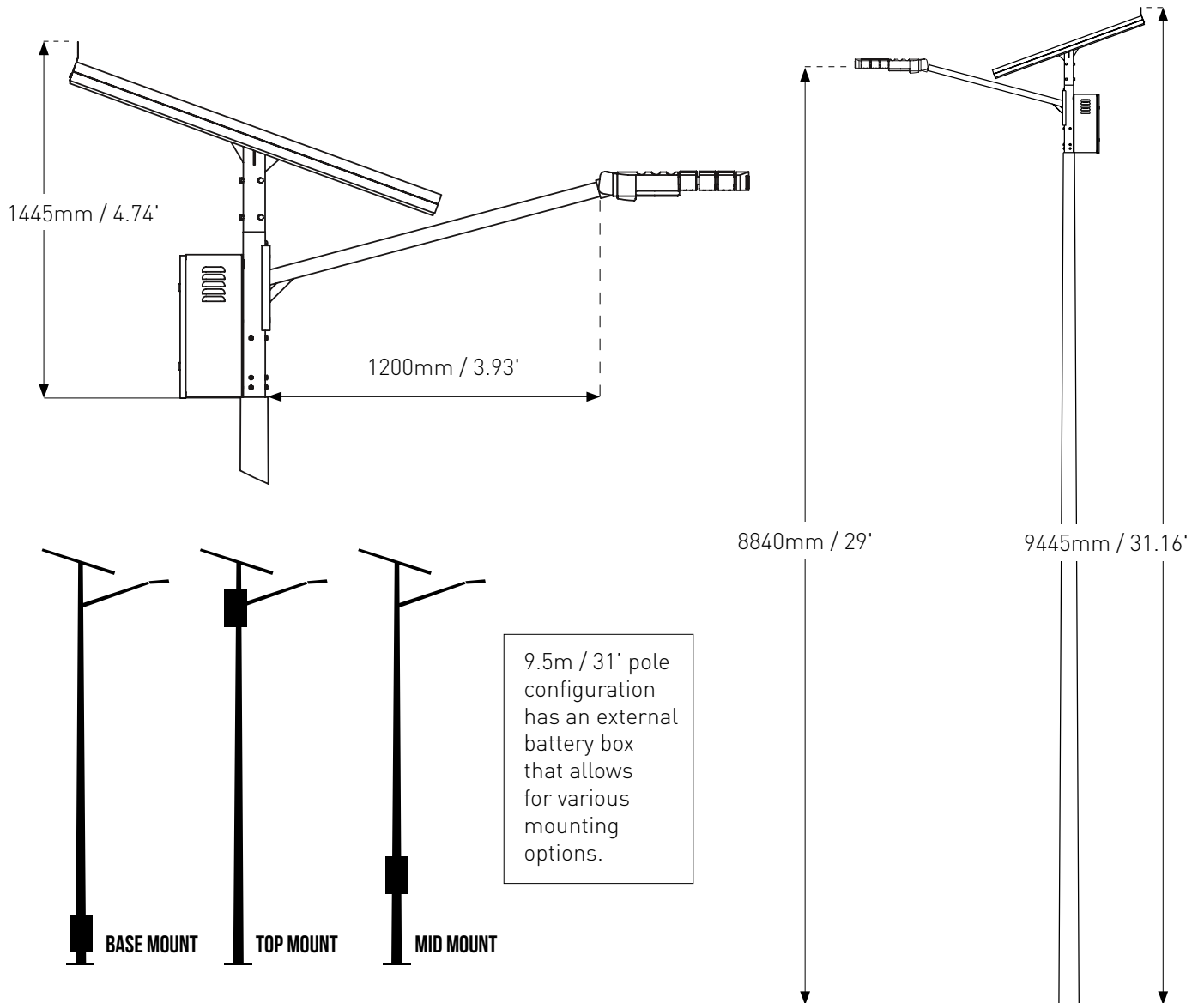

## Options

**TWIN HEAD - 180°**

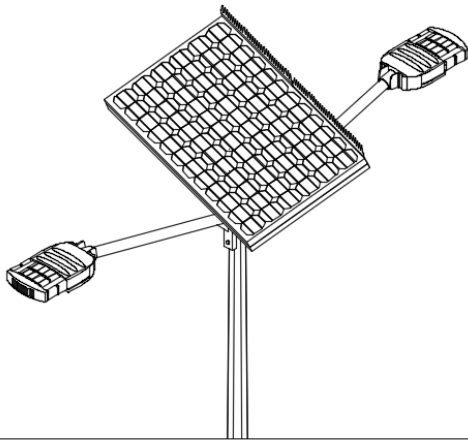

**TWIN HEAD - 90°**

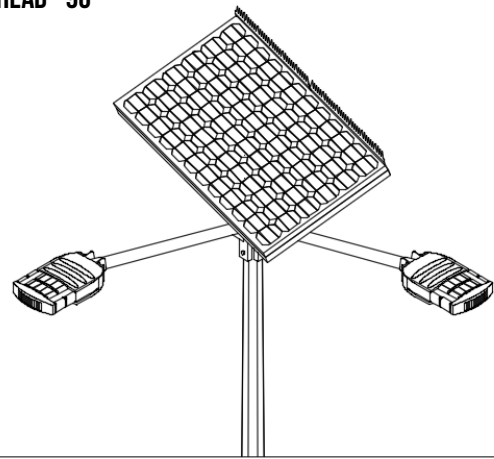

**SOLAR PANEL STONE GUARD**

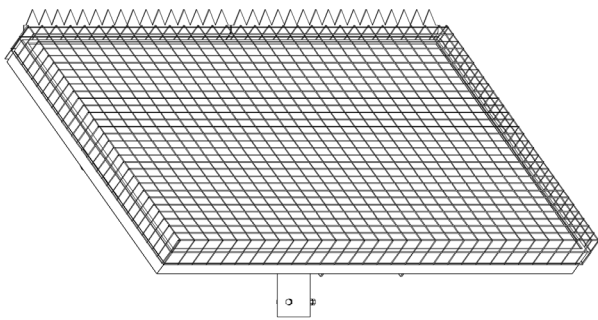

**ANTI-CLIMBING SPIKES**

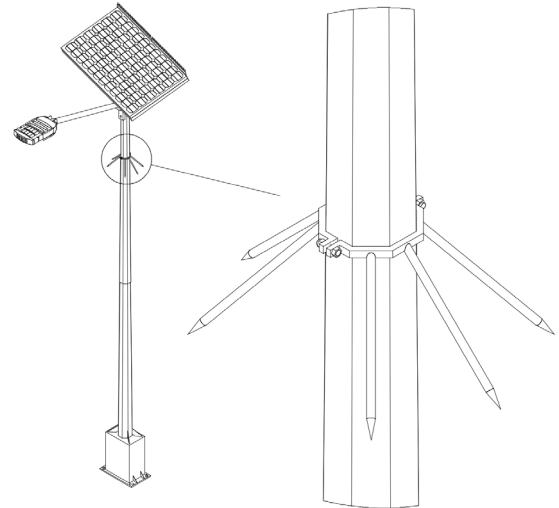

**LED STONE GUARD**

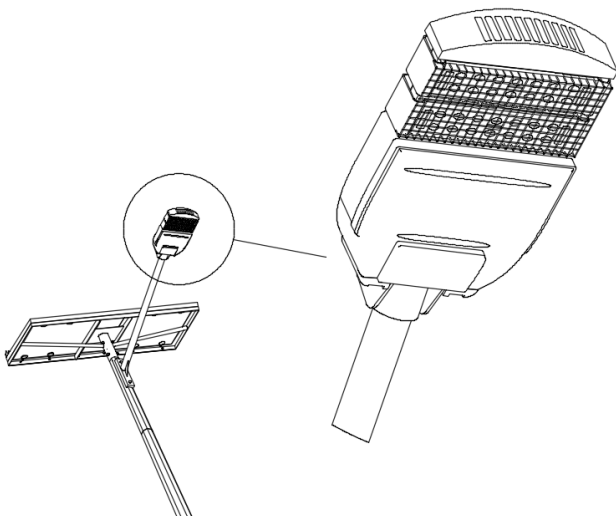

**HINGED BASE PLATE**

