

GFS-200-KT GEN 1

SOLAR STREET LIGHT KIT



FITS EXISTING POLES



30W / 60W / 75W

5,610lm / 11,220lm / 14,025lm



COMPLIANT



The GFS-200-KT is designed to be mounted onto an existing pole and replace mains powered street lighting offering an environmentally friendly, off-grid solution where traditional lighting has failed or is too costly to repair.

It has the same hardware as the GFS-200 (without the pole) and offers a reliable, vandal resistant solution that can be installed anywhere requiring reliability and performance without the costs of grid connection or energy supply.

APPLICATIONS

- Streets
- Minor Roads
- Pathways
- Car Parks
- Industrial
- Commercial
- Marinas / Jetties
- Parks / Recreation



SPECIFICATIONS

MODEL	GFS-200-KT
	GFS-200ES (TUV certified to UL1598:2018)

OPERATING PROFILE / OPERATION MODES

Standard 30W - **All night operation** - Unit operates at 100% (5610lm) until dawn.
Standard 60W - **100% for 6 hours** - Unit operates at (11220lm) then dims to 15W until dawn
Standard 75W - **100% for 4 hours** - Unit operates at (14025lm) then dims to 15W until dawn
NOTE: Configurable TIMER settings for ON / OFF / DIM are available upon request.

LED	
Type	CREE XP-G LED
Watts (Light Output)	30W 60W 75W [Other Wattages Available – Consult With Factory]
Lumens	5,610lm 11,229lm 14,025lm
CCT (Colour Temperature)	4000K [Optional 3000K, 590nm, 645nm Turtle Friendly & Narrow Band / Amber Wave]
Optics	T3 [Standard] 135° x 85° T5 [Optional] 110° x 135°

BATTERY	
Autonomy	60 hours (5 nights)*
Battery Type / Capacity	2 x 12v 110Ah (2640Wh) Sealed GEL AGM Batteries

SOLAR PANEL	
Watts (p) / Type	227W Monocrystalline
Efficiency	21%

UNIT	
Package Dimensions	Crate: 1650 x 880 x 560 mm / 65" x 35" x 22"
Package Weight	Crate: 169 kg / 372.5 lb
Product Weight	Complete Kit: 119 KG / 262.3 lb
Sail Area / EPA	0.536m ² / 5.78 FT ² @ 22° (FIXED)

ENVIRONMENTAL	
Operating Temp. Range	-20°C to 60°C / -4°F to 140°F
IP Rating	IP65 construction with IP68 waterproof connectors

WARRANTY	
Warranty Period	5 years (Unit) / 25 years (Solar Panel)**

OPTIONS	
PROTECTION	Solar panel stone guard
	LED lens stone guard
	Anti-climbing spike collar
	Light spill shield front / back
	Goose neck outrigger extension
TWIN HEAD LED OPTION	Twin head 4K CCT / 180° / 90° configuration
	Twin head 3K CCT / 180° / 90° configuration
MOUNTING / FOUNDATION	Hinged base plate (lift + lower pole without crane)
	High wind footing cage (Aust region C / D)
BATTERY BOX OPTIONS	Battery box, grey powder coated
	Battery box, stainless steel 316
	Vandal resistant battery box upgrade kit

*Based on fully charged battery at 30W / **Full warranty information is available at greenfrogsystems.com/product-warranty

PRODUCT DIMENSIONS

KIT CONTENTS INCLUDE :

1. Instruction Manual
2. Serial Number Plate
3. Wooden Packing Crate
 - Solar Panel Assembly
 - LED Light
 - Light Arm
 - Light Cable Extension
 - Bird Guard
 - Batteries (x2)
 - Solar Controller

The GFS-200-KT can be installed without requiring a certified electrician as all circuits are low voltage

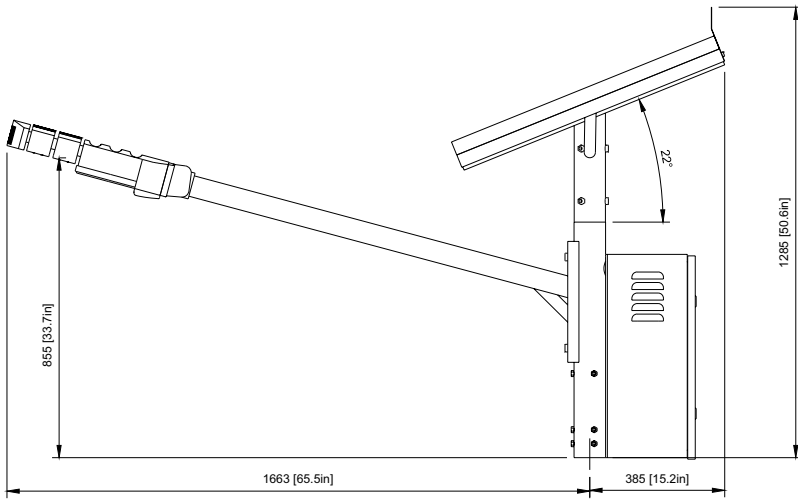
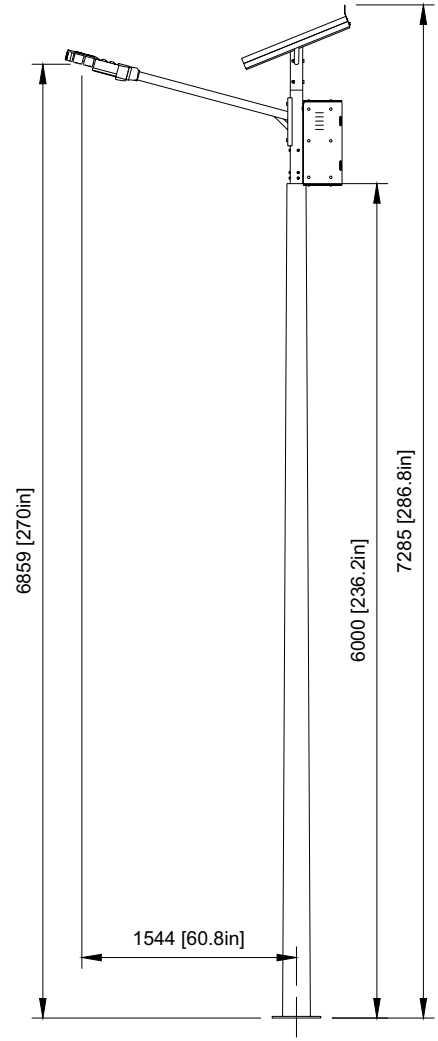
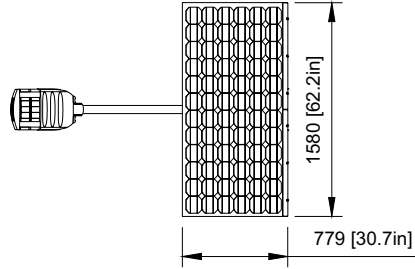

A (1:4)

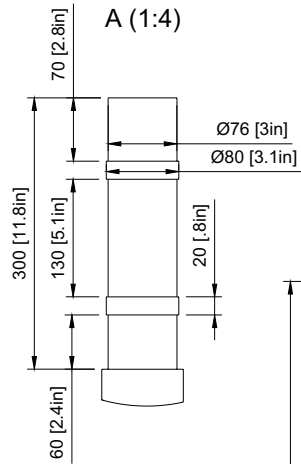
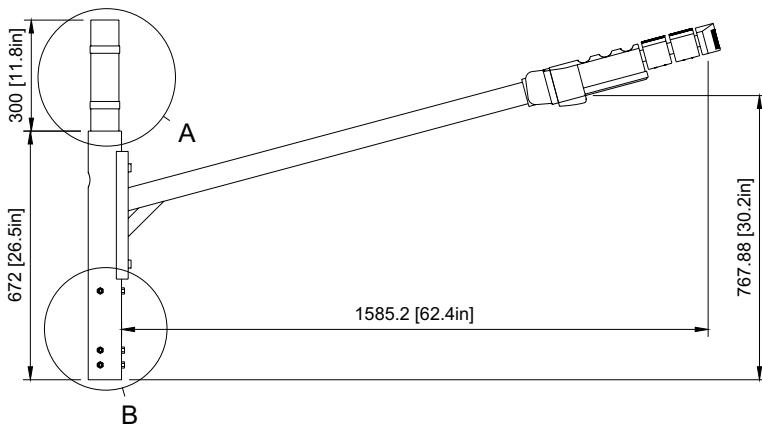

B (1:4)

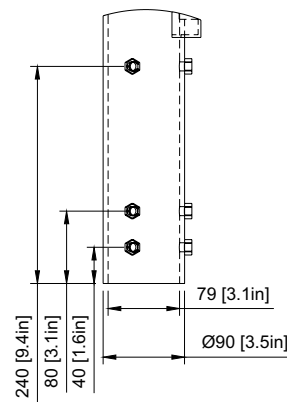

MOUNTING OPTIONS

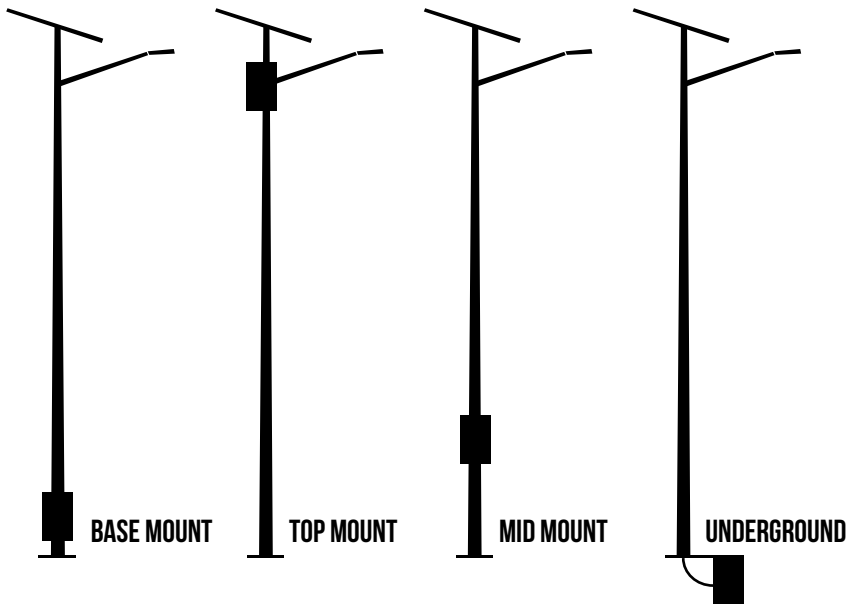

PHOTOMETRICS

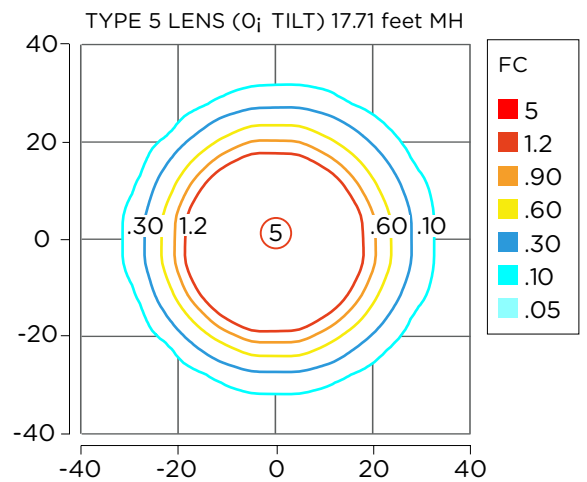
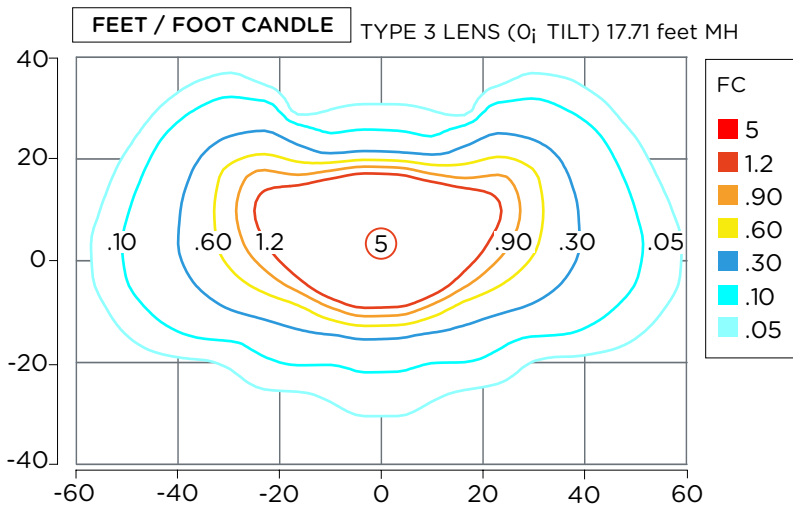
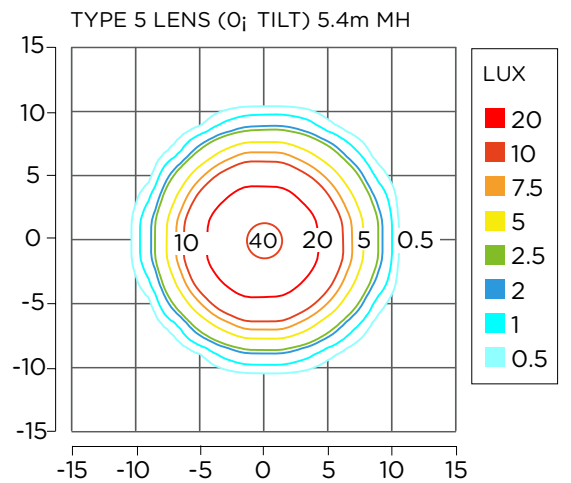
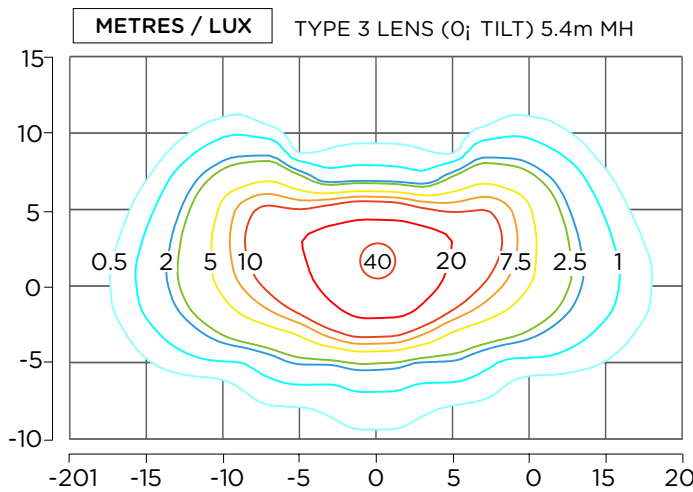

LIGHT DISTRIBUTION

FRONT VIEW

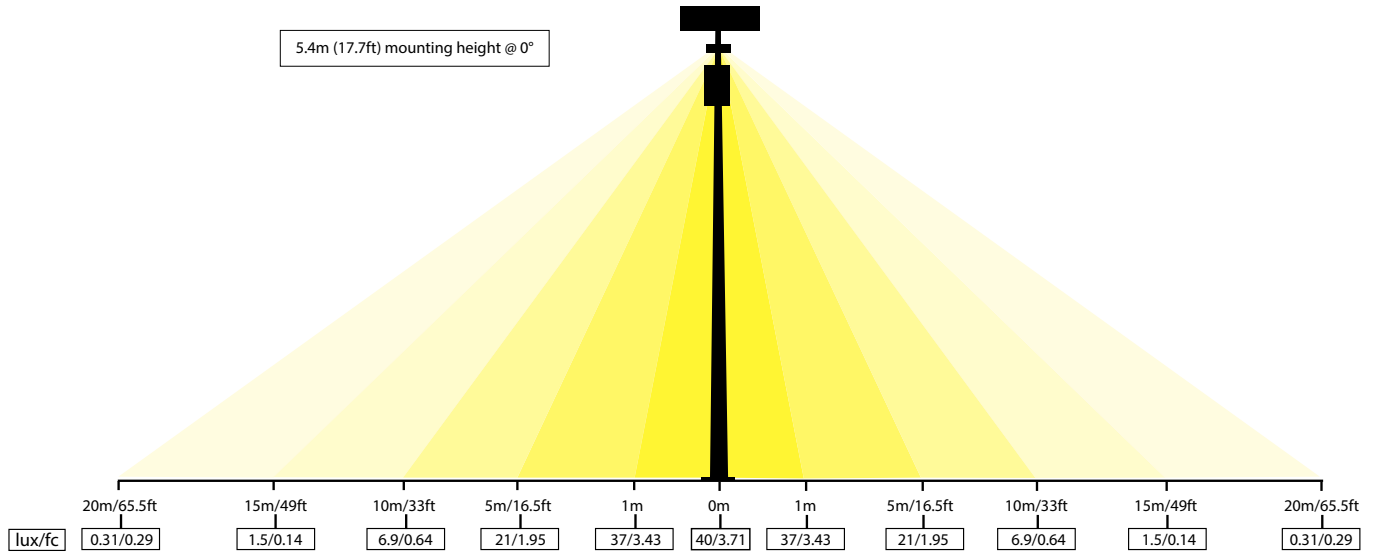

SIDE VIEW

